



## 234 Series

Washdown / Corrosion Resistant  
Industrial / Commercial Electric Unit Heater

# Owner's Manual



This manual covers installation, operation and maintenance. Read carefully before attempting to install, operate or service the 234 Series Unit Heater.

## IMPORTANT INSTRUCTIONS

**SAVE THESE INSTRUCTIONS FOR FUTURE REFERENCE**

### Heatrex

425 HANLEY INDUSTRIAL COURT • ST. LOUIS, MO 63144

314-333-5500 • FAX: 314-644-5332

www.heatrex.com • [sales@heatrex.com](mailto:sales@heatrex.com)



## **IMPORTANT INSTRUCTIONS**

Installation and maintenance personnel should familiarize themselves with this manual and all the **IMPORTANT INSTRUCTIONS** before installing or working on this heater to avoid potential unsafe conditions, severe property damage, personal injury or death.

1. Read all instructions before installing and operating this heater.
2. Verify that the supply voltage and phase to the heater matches the nameplate rating before energizing.
3. Potentially lethal voltages are present. Be sure to lock the branch circuit disconnect switch in the OFF position and tag the circuit "Out for Maintenance" before working on this equipment.
4. Keep electrical enclosure cover tightly closed while in operation.
5. Hazard of Electric Shock. Heater must be grounded in accordance with both local and national codes.
6. This heater should be installed by a licensed electrician familiar with all applicable national and local codes having jurisdiction. It is the responsibility of the installer to verify the safety and suitability of the installation.
7. Disassembly of the unit for installation is not required or authorized.
8. Replacement electrical components must be obtained from the factory in order to maintain any applicable Agency Listings.
9. Use this heater only as described in this manual. Any other use is not recommended by the manufacturer and may result in fire, electric shock or personal injury.
10. The heater and discharge air are hot when in use. To avoid burns, do not let bare skin touch hot surfaces.
11. To prevent a possible fire, do not block or allow foreign objects to enter air intakes or exhaust in any manner.
12. Risk of fire due to high temperatures. Keep electrical cords, drapery, furnishings, insulation and other combustibles at least 3 feet (0.9m) from the front of the heater and away from the sides, rear and top.
13. Installation minimum mounting clearances specified both on heater nameplate and in this owner's manual must be maintained.
14. Use copper wire rated 90°C min. for supply connections.
15. This heater should not be used in potentially explosive atmospheres. Do not use in areas where gasoline, paint, or flammable liquids are used or stored.
16. Do not use outdoors. Heater may be washed down with water for cleaning. Do not use high pressure cleaning systems.
17. Risk of fire. Do not use as a residential or household heater.
18. Heater is designed to be controlled by a room thermostat located within the operating space that will control the room temperature below 80°F (26.7°C). Do not allow heater to cycle on the built-on limit controls.
19. The heaters are designed for permanent wall or ceiling mounting in a horizontal position only.
20. Do not operate heater after it malfunctions. Disconnect power at service panel and have heater inspected by a reputable electrician before reusing.
- 21. SAVE THESE INSTRUCTIONS.**

**WARRANTY WILL BE VOID IF INSTRUCTIONS ARE NOT FOLLOWED.**

# INSTALLATION INSTRUCTIONS



## RISK OF FIRE / EXPLOSION

- This heater should not be used in potentially explosive atmospheres. Do not use in areas where gasoline, paint or flammable liquids are used or stored.
- Keep electrical cords, drapery, furnishings, insulation and other combustibles at least 3 feet (0.9m) from the front of the heater and away from the sides, rear and top.
- Installation minimum clearances specified both on the heater nameplate and in the owner's manual must be maintained.
- Do not use as a residential or household heater.

These air heaters are designed for comfort heating and should not be used in ambient temperatures exceeding 80°F (26.7°C). They are to be permanently mounted to the wall or ceiling for horizontal discharge. The unit is designed to give years of safe, trouble-free operation when properly installed and maintained.

### A. Site Selection:

The heaters are intended for elevated mounting locations so that they blow warm air down to the floor area. A mounting height should be selected so that the heater is out of the way of possible moving equipment or personnel, yet low enough to deliver warm air to the selected area. See the mechanical installation section for recommended installation heights.

Heater airflow should be directed to areas of greatest heat loss. In general, greater numbers of small heaters will provide more uniform and even heat distributions than a few large ones. In order to help move heated air around the room, multiple heaters should be spaced out and direct air in a circular pattern around the room perimeter such that each heater supports the next heater's airstreams. See Figures 1 & 2 for some typical airflow pattern arrangements:

Large room with exposed walls and roof :

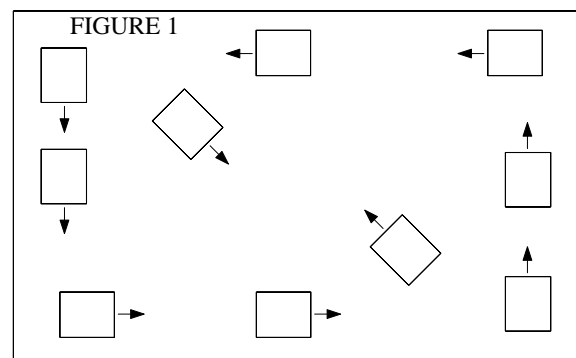

Small room with one exposed wall:

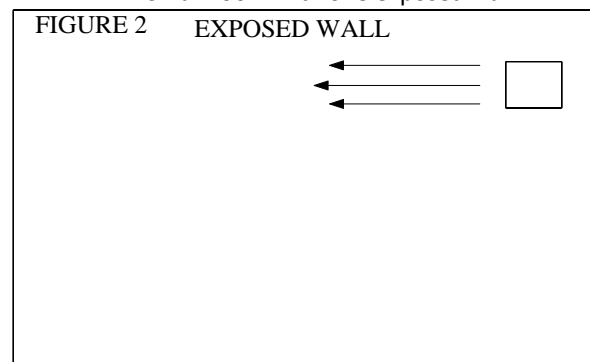

# INSTALLATION INSTRUCTIONS – Continued

## B. Mechanical Installation:

These heaters are to be mounted for horizontal discharge only. Mounting is to be accomplished by using either (4) 3/8x16 threaded rods (supplied by others) or the stainless steel swivel mounting bracket factory supplied with the heater. Lock washers should be used on all mounting nuts and bolts to ensure they don't vibrate or work loose due to fan vibration or other vibration transmitted to the heater.

The supporting structure that the heater is attached to must have adequate strength to safely support the heater. The heater dimensions and maximum unit weights are:

TABLE 1:

KW	Cabinet Size	X	Y	Z	Weight
<= 12	1	15.50" (394mm)	21.50" (546mm)	13.00" (330mm)	56 lbs (25 kg)
12.1 to 47	2	26.00" (660mm)	28.00" (711mm)	20.00" (508mm)	115 lbs (52 kg)

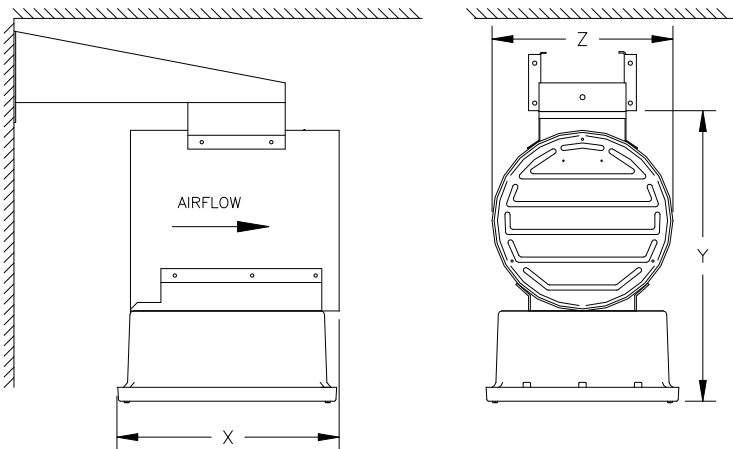

Select a location for installation such that the outlet air is not directed at an adjacent wall. Louvered grills can be installed to deflect the discharge air up, down or sideways.

TABLE 2:

KW	Cabinet Size	Air Volume	Air Throw	Outlet Velocity
<= 7.5	1	700 CFM (1189 cubic m/hr)	26 Ft (8 m)	760 FPM (232 m/min)
7.6 to 12	1	1450 CFM (2463 cubic m/hr)	43 Ft (13 m)	1575 FPM (481 m/min)
12.1 to 47	2	2400 CFM (4077 cubic m/hr)	50 Ft (15 m)	1200 FPM (366 m/min)

Once an acceptable location has been determined, see the following instructions to complete the mechanical installation:

1. To ensure proper heating of floor surfaces, observe the following recommended mounting height limitations (to bottom of heater):

<= 5 KW	5.1 to 10 KW	10.1 to 20 KW	20.1 to 47 KW
10' (3m)	15' (4.6m)	20' (6.1m)	25' (7.6m)

2. Install the heater at least 6 feet (1.8m) from the floor and 8" (203mm) from the wall or ceiling.
3. Mount heater using one of the following two options:

Standard ceiling or wall mount using the swivel bracket:

MOUNTING HOLE DETAIL-  
REAR VIEW OF BRACKETS

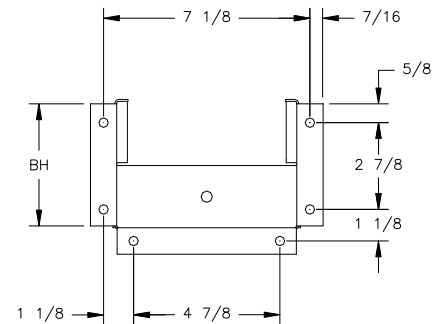

FIGURE A  
(1-12KW)

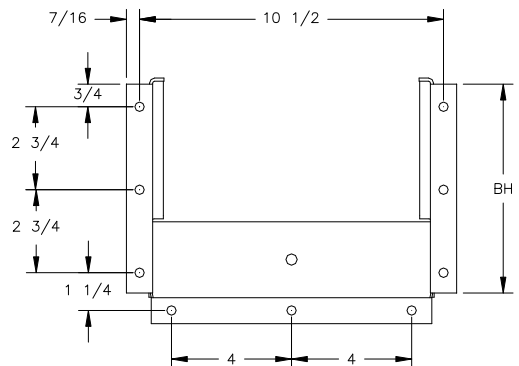
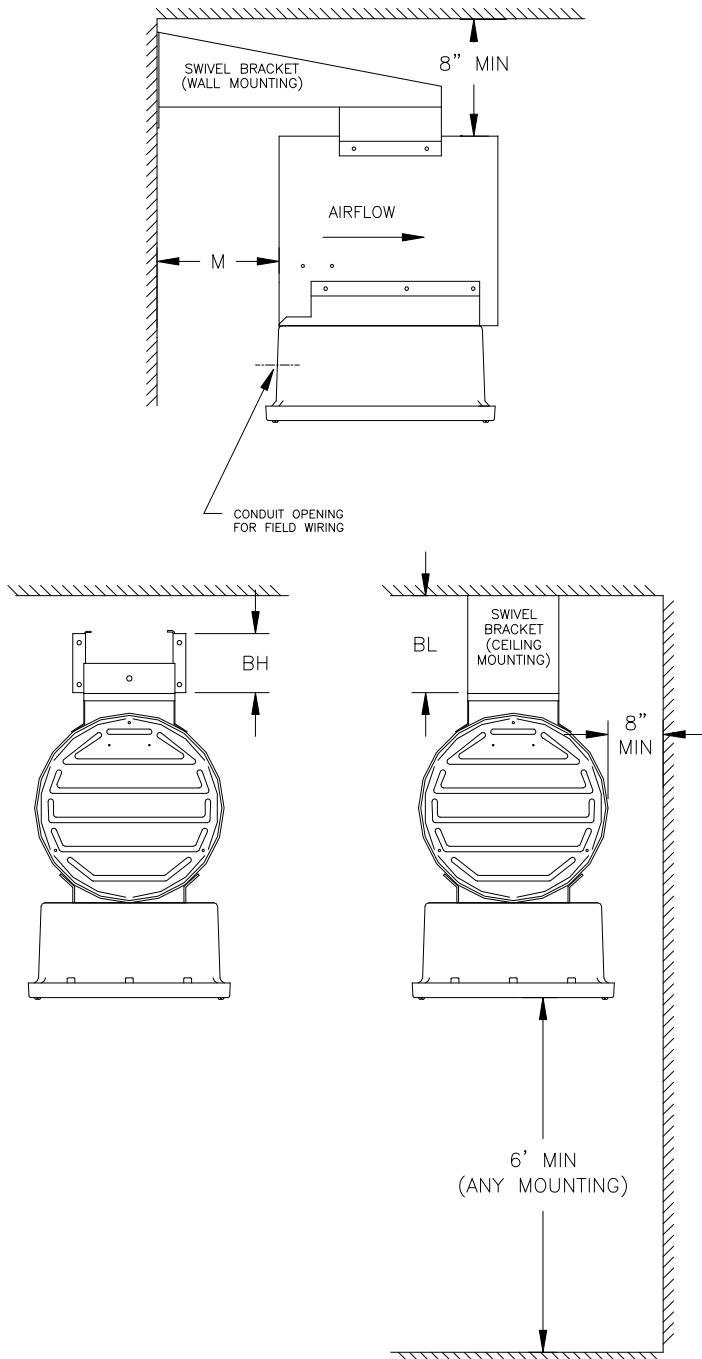

FIGURE B  
(12.5-47KW)

(See Table 4 on next page for tabulated dimensions)

# INSTALLATION INSTRUCTIONS – Continued

## Ceiling or wall mount using swivel bracket (cont):



## Optional Ceiling Installation using 4 threaded rods:

For ceiling installation using threaded rods, secure the four rods to the ceiling using locknuts.

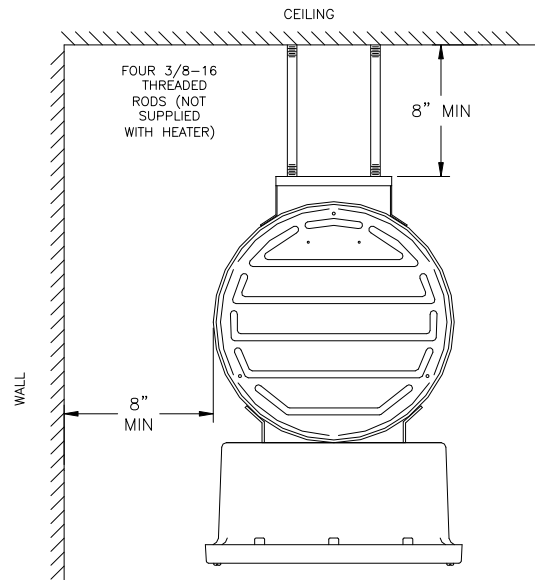

TABLE 4:

KW	BH	BL	M
≤ 12	4.25" (108mm)	19.50" (495mm)	8.50" (216mm)
12.1 to 47	7.125" (181mm)	22.25" (565mm)	3.25" (83mm)

## INSTALLATION INSTRUCTIONS - Continued



### ELECTRIC SHOCK HAZARD

- Electrical installation should be made by a qualified licensed electrician. Wiring procedures, connections and grounding shall be in accordance with the national and local codes having jurisdiction.

#### C. Electrical Installation:

Follow these instructions to complete the electrical installation:

1. External branch circuit protection is required. See nameplate ratings and follow Code recommendations.
2. Follow the national and local electrical and building codes related to the installation and intended use of the heater.
3. When doing any work on a heater, including the initial electrical connection, disconnect the electrical supply at the main branch circuit switch, and lock the switch in the off (open) position. Tag the circuit "Out for Maintenance" to prevent potential lethal shock hazards.
4. Confirm that the electrical power supply matches the nameplate voltage, phase, amperage and frequency rating of the heater to be connected.
5. Field supply conductors must be sized for at least 125% of the circuit current. The circuit current in amps is calculated as follows:

$$\text{Single Phase Amperage} = \frac{\text{Circuit kW} \times 1000}{\text{Circuit Voltage}}$$

$$\text{Three Phase Amperage} = \frac{\text{Circuit kW} \times 1000}{1.732 \times \text{Circuit Voltage}}$$

6. Use copper conductors rated 90°C minimum with watertight conduit fittings.
7. Field wiring to the heater must comply with all branch circuit requirements of any national and local codes having jurisdiction.
8. Proper installation of the heater requires that an adequate grounding conductor be connected to the ground terminal. This terminal marked with the letter "G" and is located on the inside of the control enclosure.
9. A wiring diagram is supplied with each heater and is located on the inside surface of the control enclosure cover.
10. Check and confirm all connections are securely tightened. Remove any foreign objects from the control box and close access door.
11. See section titled "Operating Instructions" before energizing the heater.

# **OPERATING INSTRUCTIONS**



## **RISK OF FIRE / EXPLOSION**

- This heater should not be used in potentially explosive atmospheres. Do not use in areas where gasoline, paint or flammable liquids are used or stored.
- Keep electrical cords, drapery, furnishings, insulation and other combustibles at least 3 feet (0.9m) from the front of the heater and away from the sides, rear and top.
- To prevent a possible fire, do not block or allow foreign objects to enter air intakes or exhaust in any manner.



## **ELECTRIC SHOCK HAZARD**

- Keep electrical enclosure cover tightly closed while in operation.
- Do not operate heater after a malfunction. Disconnect power at service panel and have heater inspected by a reputable electrician before reusing.
- Use this heater only as described in this manual. Any other use is not recommended by the manufacturer and may result in fire, electric shock or personal injury.



## **RISK OF INJURY / BURN**

- The heater and discharge air are hot when in use. To avoid burns, do not let bare skin touch hot surfaces.
- Do not attempt to service or clean heater while unit is operating as there is a hazard from electric shock, injury from operating fan blade and burns from hot heating elements.

The unit is designed to give years of safe, trouble-free operation when properly installed and maintained. Please read the following guidelines to ensure reliable operation:

1. Confirm proper mechanical and electrical installation before operation of the heater.
2. This unit heater may be operated at ambient temperatures of 80°F (26.7°C) or less.
3. Make sure the wiring enclosure cover is closed securely.
4. Set the temperature control thermostat to a setting above the current room temperature.
5. If the heater is provided with a selector switch, it must be in the ON position.
6. Energize the heater electrical supply circuit.
7. The heater and fan should come on.
8. Check for the correct fan blade rotation. If air is not discharging through the louvers, interchange any two of the three field supplied power leads on three phase units only.
9. Since the heater is equipped with a built-in time delay relay, the fan will remain in operation for about a minute to cool the elements after the heater is switched off either by the thermostat or the selector switch. Do not turn the heater off at the main disconnect switch, as this will prevent the fan from cooling elements.

## **OPERATING INSTRUCTIONS - Continued**



### **RISK OF FIRE / EXPLOSION**

- This heater should not be used in potentially explosive atmospheres. Do not use in areas where gasoline, paint or flammable liquids are used or stored.
- Keep electrical cords, drapery, furnishings, insulation and other combustibles at least 3 feet (0.9m) from the front of the heater and away from the sides, rear and top.
- To prevent a possible fire, do not block or allow foreign objects to enter air intakes or exhaust in any manner.



### **ELECTRIC SHOCK HAZARD**

- Keep electrical enclosure cover tightly closed while in operation.
- Do not operate heater after a malfunction. Disconnect power at service panel and have heater inspected by a reputable electrician before reusing.
- Use this heater only as described in this manual. Any other use is not recommended by the manufacturer and may result in fire, electric shock or personal injury.



### **RISK OF INJURY / BURN**

- The heater and discharge air are hot when in use. To avoid burns, do not let bare skin touch hot surfaces.
- Do not attempt to service or clean heater while unit is operating as there is a hazard from electric shock, injury from operating fan blade and burns from hot heating elements.

The unit is designed to give years of safe, trouble-free operation when properly installed and maintained. Please read the following guidelines to ensure reliable operation:

10. During normal operation, the limit controls are not supposed to cycle the heater ON and OFF. If frequent cycling of the limit controls occurs, verify the minimum mounting clearances are maintained, proper operation of the room thermostat and that there is no visible obstruction to the heater inlet or outlet. If this does not eliminate the limit control cycling, the heater must be examined by qualified service personnel before further operation to determine the cause.
11. Heater may be provided with a manual reset limit control (order code M). This limit control disables the electrical function of the heater whenever excessive temperatures are present. If the manual reset limit control is suspected of causing heater non-function then the heater must be disconnected from the heater electrical supply and examined by a qualified service personnel. The personnel must determine the cause of the excessive temperatures, verify the minimum mounting clearances, verify proper orientation of the heater, verify proper orientation of the room thermostat, or if there are any obstructions or damage to the heater or heater inlet or heater outlet. The manual reset limit control may be reset, after determining the cause, by removing the electrical enclosure cover and pressing on the manual reset button. The location of the manual reset button within the electrical enclosure is shown in the Maintenance Instructions.
12. Check out and report any unusual or questionable operating characteristics, such as noise, vibration, etc.
13. Set the temperature control thermostat to the desired room temperature setting and place unit in service.



# MAINTENANCE INSTRUCTIONS



## ELECTRIC SHOCK HAZARD

- Potentially lethal voltages are present. Be sure to lock the branch circuit disconnect switch in the OFF position and tag the circuit “Out for Maintenance” before working on this equipment.



## RISK OF INJURY / BURN

- Do not attempt to service or clean heater while unit is operating as there is a hazard from electric shock, injury from operating fan blade and burns from hot heating elements.
- Maintenance and repair must be performed by qualified service personnel only.

### Electrical:

1. Inspect all terminal connections, contactors and conductor insulation for damage, looseness, fraying, etc., as applicable. Tighten any loose terminals and replace or repair wire that has damaged or deteriorated insulation. Replace any contactor that has contacts that are badly pitted, welded together, or burned.
2. If reduced heat output is suspected, perform the mechanical checks. If low heat output is still suspected after completing the mechanical checks, verify the condition of the heating elements by visual inspection and by using an amperage meter to check the current draw of each input line. Adjust the room thermostat to its highest temperature to energize heater. All input lines should draw approximately equal current which should agree with the nameplate rating. If they do not, one or more of the heating elements could be burned out and should be replaced.
3. For heaters supplied with the optional manual reset limit control (order code ‘M’), the electrical enclosure cover must be opened to gain access to the reset button. See below to locate the reset button:

### Mechanical:

1. Before cleaning or servicing, ensure power has been turned off at the service panel and the heating elements are cool.
2. Annually check the tightness of all visible bolts and nuts, in particular the support structure bolts and nuts.
3. Periodically, check the motor, fan, discharge openings, intake openings, heating elements and control compartment for cleanliness. If necessary, clean by using a vacuum or compressed air. Be careful not to bend or distort the fan blade propeller.
4. Check fan motor for smooth running operation. Any unusual noise or vibration must be investigated and rectified.
5. The electric motors are permanently lubricated and thermally protected. Check for smooth and quiet operation at all inspections. Replace motor if excessive bearing play is detected.
6. The heater may be washed down with water. Do not use high pressure cleaning systems.

MANUAL RESET BUTTON

