

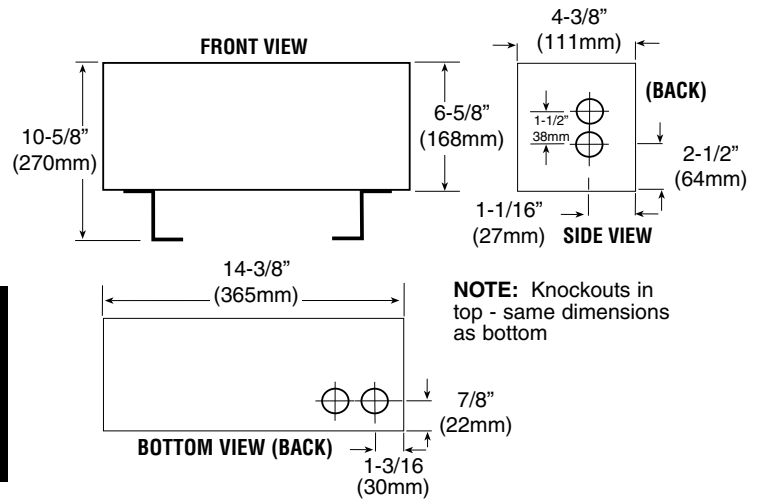

WIX-RBB-W Back Box (For R and G Series Wall Heaters)



Installation & Maintenance Instructions

⚠ **WARNING** ⚠

Read Carefully - These instructions are written to help you prevent difficulties that might arise during installation of heaters. Studying the instructions first may save you considerable time and money later. Observe the following procedures, and cut your installation time to a minimum.

CAUTION - TO REDUCE RISK OF FIRE AND ELECTRIC SHOCK:

1. Disconnect all power coming to heater at main service panel before wiring or servicing.
2. All wiring must be in accordance with the National and Local Electrical Codes and the heater must be grounded.
3. Verify the power supply voltage coming to heater matches the ratings printed on the heater nameplate before energizing.
4. This heater is hot when in use. To avoid burns, do not let bare skin touch hot surfaces.
5. Do not insert or allow foreign objects to enter any ventilation or exhaust opening as this may cause an electric shock, fire or damage to the heater.
6. Do not block air intakes or exhaust in any manner. Keep combustible materials, such as crates, drapes, etc., away from heater. Do not install behind doors, furniture, towels or boxes.
7. A heater has hot and arcing or sparking parts inside. Do not use it in areas where gasoline, paint or flammable liquids are used or stored.
8. Use this heater only as described in this manual. Any other use not recommended by the manufacturer may cause fire, electric shock, or injury to persons.
9. This heater is not approved for use in corrosive atmospheres such as marine, green house or chemical storage areas.
10. Heater must only be installed in a horizontal direction (motor & thermostat to right) as shown in this manual. Do not install sideways or upside down.
11. Heater must be installed with Back Box.
12. For wall mounting only. The following minimum clearances must be maintained: Heater to floor - 4 in. (102 mm); Heater to any adjacent wall - 6 in. (152 mm); Heater to ceiling - 36 in. (915 mm).
13. When wiring, power supply must enter through knockouts in right end of back box. Do not use the knockouts in left end of back box.
14. Do not operate heater without grille installed.
15. Do not use heater for dry out. Paint, plaster, sawdust and dry-wall sanding dust will damage heater and must be kept out of heater.
16. Grille and discharge air are hot when in use. Do not install or use heater in any area where the airflow from heater may be obstructed. Hot air may damage certain fabrics and plastics. Always keep electrical cords, bedding, furniture and other combustibles away from heater.

SAVE THESE INSTRUCTIONS

The WIX-RBB-W back box is designed for recessed installation in standard 2 x 4 (50mm X 100mm) or larger stud walls with the back box mounted as shown in either Fig. 1, or Fig. 2.

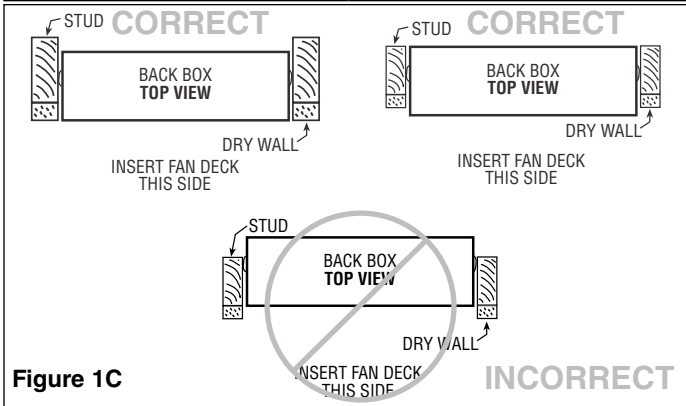
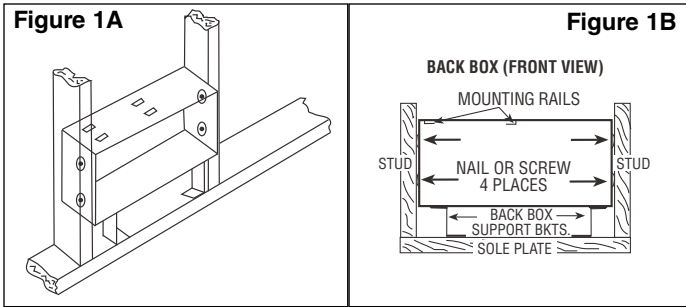

The R series and G series heaters may be wired with standard building wiring (rated minimum 60° C). Refer to Table 2 (Page 3) for appropriate wire size for total current (amps) for the circuit supplying power to your heater (see heater nameplate).

TOTAL AMPS	WIRE SIZE (COPPER)	CIRCUIT BREAKER OR FUSE SIZE
0 thru 12	#14	15 Amps
12.1 thru 16	#12	20 Amps
16.1 thru 24	#10	30 Amps

**TO INSTALL BACK BOX (Model WIX-RBB-W)
IN NEW CONSTRUCTION - WALL STUDS 16" ON CENTER.
(REFER TO FIG. 1)**

NOTE: Please review warning 12 on page 1.

1. Locate back box (model WIX-RBB-W) and back box support brackets (2). Back box must be installed with mounting rails to the top (see Fig. 1B).
2. Install back box support brackets with foot tabs directed towards the center of the back box as shown in Fig. 1A and 1B. It may be necessary to bend up slightly the tab on the back box support bracket to allow insertion under the mounting lances on the bottom of the back box.
3. Determine which knockout in back box will be used for field wiring and remove (see back box drawing page 1). Install strain relief (field supplied). See warning No. 13.
4. Fish field wiring through strain relief leaving 6" of wire inside box.
5. Insert back box assembly into wall. The front of the back box should be flush with the finished wall surface provided if the rear does not protrude beyond the stud (see Fig. 1C). The back box support brackets should be resting on the sole plate of the stud wall to insure proper spacing and leveling (see Fig. 1B).
6. Using four (4) wood screws or drywall screws or four (4) nails (field supplied), secure back box to studs (see Fig. 1B). Back box support brackets can now be removed. If not removed, secure to sole plate.

**TO INSTALL BACK BOX IN NEW CONSTRUCTION -
WALL STUDS SPACING GREATER THAN 16" ON CENTER.
(REFER TO FIG. 2)**

NOTE: Please review warning 12 on page 1.

NOTE: Fig. 2 depicts the back box installed with the left side adjoining stud. For a box with the right side adjoining a stud, reverse the directions shown below.

1. Locate back box and back box support brackets (2). Back box must be installed with mounting rails to the top (see Fig. 2B)
2. Determine which side of the back box will adjoin stud and insert back box support bracket on that side with foot tab directed towards center of back box. On the side of the back box that will not adjoin stud, install back box support bracket on that side with foot tab directed towards end of box and secure to box with 3/8" long sheet metal screw (provided)(see Fig. 2A).

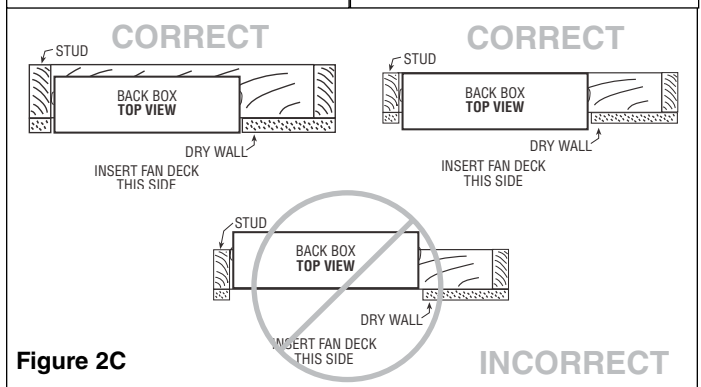
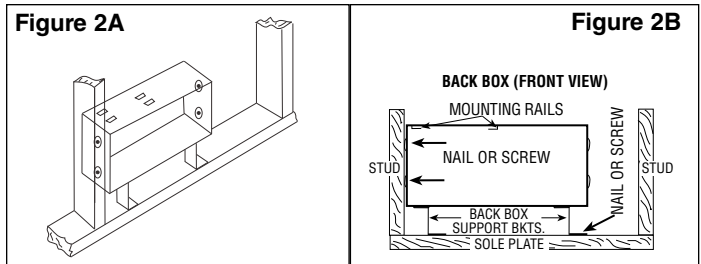

3. Determine which knockout in back box will be used for field wiring and remove (see back box drawing page 1). Install strain relief (field supplied).
4. Fish field wiring through strain relief leaving 6" of wire inside box.
5. Insert back box assembly into wall. The front of the back box should be flush with the finished wall surface provided if the rear does not protrude beyond the stud (see Fig. 2C). The back box support brackets should be resting on the sole plate of the stud wall to insure proper spacing and leveling (see Fig. 2B).
6. Use two (2) wood screws or drywall screws or two (2) nails (field supplied) to secure the side of the back box that adjoins a stud. Use one (1) wood screw or drywall screw or one (1) nail (field supplied) to secure the foot tab of the back box support bracket (that is on the end opposite the stud) to the sole plate (see Fig. 2B).

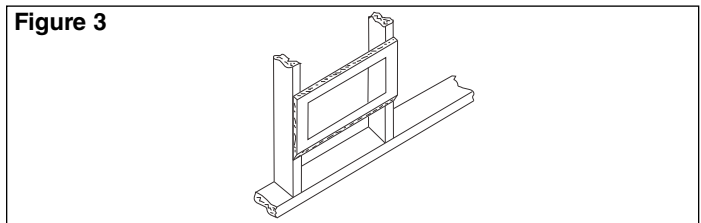

**TO INSTALL BACK BOX IN
EXISTING CONSTRUCTION**

NOTE: Please review warning 12 on page 1.

1. Locate wall studs to be sure that entire cut-out can be made between studs. At least one side of the cut-out must be flush with side of the stud. Bottom of cut-out must be 4" above finished floor minimum. Make a cut-out in wall 14-1/2" wide X 6-3/4" high (368mm X 171mm) (see Fig. 3).
2. Determine which knockout in back box will be used for field wiring and remove (see back box drawing, page 1). Install strain relief (field supplied).
3. Fish field wiring through strain relief leaving 6" of wire inside box.
4. Insert back box into cut-out. The front of the back box should be flush with the finished wall surface provided if the rear does not protrude beyond the stud (see Fig. 1C or 2C).

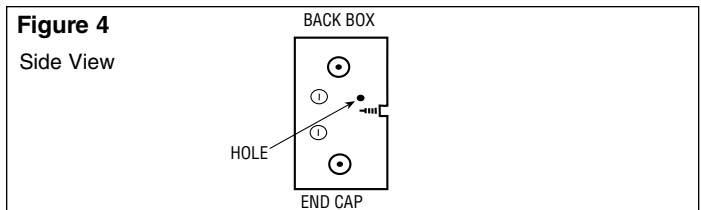

5. Using four (4) wood screws or drywall screws (field supplied) or four (4) nails (field supplied), secure back box to studs (see Fig. 1B). If wall studs are greater than 16" on center, use only 2 fasteners and on the opposite end of the back box drive a 1" sheet metal screw (provided) through hole in end of back box. This will draw the back box tight with drywall when grille is installed. (See Fig. 4.)