



INSTALLATION, OPERATING & MAINTENANCE INSTRUCTIONS FOR 797 & 798 SERIES PIPE INSERT HEATERS

GENERAL

HEATREX Pipe Insert Heaters are designed to provide years of trouble free operation if properly installed and maintained. Please read and follow these instructions for installing and maintaining the heater.

Pipe Insert Heaters provide an effective way to heat large storage tanks. The heating element design allows removal and servicing of the heating element without draining the tank.

HEATER CONSTRUCTION

The heating elements are open coil design and consist of heavy gauge nickel-chromium alloy supported by ceramic insulators. The ceramic insulators are fastened to a strip of heavy sheet metal.

PIPE / TUBE CONSTRUCTION

The heaters shall be installed in a tube or pipe of sufficient wall thickness to prevent the tube from distorting from the heat generated. The tubes shall be constructed so that the heating elements may be removed without draining the tank. When specified, HEATREX can provide heater pipes (798 series).

For additional product offerings, refer to HEATREX catalog literature on Process Heating such as Circulation Heaters, Immersion Heaters, or Tubular Heating Elements. Refer to HX87-2000-83 for Industrial Control Panel IOM.

A variety of designs, sizes, and mounting configurations are available. The heater watt density and design features must be closely matched to the application.

Life of the heating element is directly related to its surface temperature.

CAUTION

Failure to follow HEATREX recommendations could result in premature failure and/or serious equipment damage.

Temperature regulating devices, temperature limiting controls, and low liquid level controls are recommended for use with pipe insert heaters, to control the heating process and safeguard the heater from excessive temperatures that can cause damage. Also, damage to fluid could occur if the heater is allowed to exceed the maximum film temperature recommended by the manufacturer. Heaters can be provided with sheath sensing thermocouples when requested.

HEATREX Pipe Insert Heaters can be specially designed for use in hazardous areas as specified in Article 500 through 516 of the National Electrical Code. Refer to the heater nameplate or HEATREX Application Data for classification of the heater provided. See section below labeled Hazardous Areas for specific requirements.

It is the ultimate responsibility of the user to verify that the construction materials provided by HEATREX are suitable for use with the process fluid. Specifically, corrosion issues must be reviewed. Refer to HEATREX Application Data for heater construction materials and design conditions.

INSTALLATION

CAUTION

HEATREX recommends installation be performed by qualified personnel familiar with the National Electrical Code and all local codes and standards. It is the responsibility of the installer to verify the safety and suitability of the installation

WARNING

DO NOT mount heaters in an atmosphere containing combustible gases, vapors, dusts, or fibers unless properly marked as suitable for the condition. Refer to section below for special instructions for Hazardous Areas.

WARNING

Hazardous voltages are present in this equipment. Lock out and tag the branch circuit disconnect switch before working on this heater.

Handling and Storage

Care must be taken to avoid damage to the heater during storage and handling. When HEATREX provides heaters with pipes, the heating element is shipped in the pipe. If the heater pipe is user supplied, the heating element will be shipped in cardboard shipping tubes.

Protect the heater from weather damage during storage. Cardboard shipping tubes are not suitable for outdoor storage.

It is recommended to store the heater in a cool dry area to help prevent the heating element ceramic spacers from drawing moisture.

Mechanical Instructions

Site Selection

Review the NEMA Type rating of the heater noted on the HEATREX Application Data. Do not install a heater in an area not consistent with its rating.

Allow sufficient free space around heater installation site. Work space for heater maintenance should be at least three feet in front and on either side of the heater. The minimum pull space for the heating element installation or removal from the pipe/tube should be at least four feet. The heating element is designed to be flexible and can be curved if necessary.

Electric heaters are capable of developing high temperatures. Therefore, extreme care should be taken to

avoid mounting heaters in an atmosphere containing combustible gases, vapors, dusts, or fibers unless properly marked as suitable for the condition.

Heater Orientation

This style of heater is intended for horizontal use only. The open coil resistance wire must not be mounted in a vertical orientation or failure could occur from the coil sagging.

The heater must be mounted plumb horizontally to assure proper operation.

Thermal expansion of the heater pipes must be considered when locating the heater. It can be approximated as:

$$\text{Pipe Length (Inches)} \times .00001 \times \left[\begin{array}{l} \text{Max Pipe} \\ \text{Operating} \\ \text{Temp (}^\circ\text{F)} \end{array} - 70^\circ\text{F} \right]$$

If the heater is installed in a pressurized tank, a relief valve must be installed. As a minimum, the valve must be sized to relieve at a rate equal to the rate that the heater can thermally expand fluid in the tank.

Pipe Installation

On heater pipes provided with ANSI flanged connections, take care to prevent scratching the flange faces. HEATREX supplies a non-asbestos nitrile bonded fiber flange gasket unless otherwise requested. The user must confirm that the gasket is suitable for the application. The user must supply high strength studs or bolts and nuts, such as A-193 GR. B7 and A194 GR. 2H, rated for the design conditions. Bolts must be properly installed and tightened to prevent leaks.

When heater pipes are welded directly to the user's tank wall, remove the heating element from the pipe before welding. Refer to the following instructions for handling and removing heating elements.

Heater pipes must be supported inside the user's tank. Supports must not prevent the pipes from thermally expanding. Supports should be located on a maximum spacing of 10 feet.

Where buildup of solids in the bottom of the tank is expected, the pipe must be located above that level. The pipe must also be located below the minimum operating fluid level of the tank.

Heater pipes must be perfectly clean before installation of heating element. Use only a clean dry cloth to clean. Never use

a lubricant. Compressed air with a long wand may be used to remove ceramic chips, etc.

If the heater pipe is not supplied by HEATREX, ensure the pipe length is correct by measuring the heating element overall length (OAL), the cold length from the start of the coiled wire to the front end of the heating element (CL), and the length of the heater pipe not including the pipe cap (PL).

The pipe length PL must be greater than or equal to OAL. When locating the heater pipe in the tank, the distance from the front end of the pipe to the exterior tank wall must be less than or equal to CL to ensure the heated area is in the fluid.

Heating Element Installation & Removal

To remove the heating element from a heater pipe or shipping tube, first remove the fastening nut at the terminal end. Hold the ceramic insulator firmly in order to avoid undue pressure on the ceramic and possible breakage. If obstructions are encountered, rotate the heater slightly back and forth while pulling out.

Since heating elements can be of considerable length, it may not always be possible to remove the element in a straight line, due to space limitations. Since the element bar is flexible, the element may be curved on a radius of 4 feet minimum. It is recommended that at least 2 people be used for this procedure, in order to avoid breaking the ceramics.

After the element bar has been removed, it should be carefully stretched out on a clean table for inspection. Broken ceramics must be replaced and burn spots should be cleaned with a dry clean paper or cloth towel. Oil or other contamination on the heater will cause a failure.

When installing the heating element into the heater pipe, reverse the steps noted above.

Heater pipes must be perfectly clean before installation of element. Use only a clean dry cloth to clean. Never use a lubricant. Compressed air with a long wand may be used to remove ceramic chips, etc.

The heating element intended only to be installed with the sheet metal strip on the bottom. Do not rotate the heater in the pipe.

CAUTION -Hazard of Electric Shock
Heaters must be bolted into position at the terminal end to prevent movement, which could allow the heater to short out against the pipe.

See figures attached for mounting configurations.

Thermal insulation must be installed between the first few ceramics in the "cold" section of the heater where the resistance wire is not coiled. A loose fill cerafiber (HEATREX P/N 1008466) or equal, rated for 2000°F, is preferred. The insulation must be free of moisture or contamination in order to provide electrical isolation. The insulation is necessary to allow 90°C rated field wiring.

Insulation

WARNING

Surfaces of the heater pipe extending beyond the user's vessel may be extremely hot. Avoid contact to prevent personnel injury or fire.

The customer may prefer to insulate the flange or pipe at the tank for personnel safety and energy conservation.

WARNING

Do not insulate the terminal enclosure or the first 2" of the pipe. Dangerous over-heating of the terminal box wiring could result.

The heating elements are provided with a "cold section" where stainless steel bussing is used to connect to the heating coils. This area must be packed with insulation to prevent over-temperature of the terminal enclosure. Refer to warning above.

Electrical Instructions

The potentially high operating and ambient temperatures of Pipe Insert Heaters require field wiring to the heater to be carefully matched to the application to avoid serious injury or damage to the equipment. The wiring must be de-rated for the expected terminal box temperature. If the cold section of the heater is properly insulated, 90°C minimum wire may be used. Refer to the National Electrical Code.

The size and type of incoming field wiring will depend upon the heater terminal box temperature. The terminal box temperature is a function of the maximum outlet temperature, heater current draw per conductor, number of conductors per conduit, and wire insulation rating. Field supplied conductors must be sized for at least 125% of the circuit current.

To calculate the circuit current (in amps):

$$\text{Single phase Line current} = \frac{\text{KW} \times 1000}{\text{Line Voltage}}$$

$$\text{Three phase Line current} = \frac{\text{KW} \times 1000}{1.732 \times \text{Line Voltage}}$$

Wiring to the heater should be permanently installed in metallic or non-metallic electrical grade conduit in accordance with all applicable electrical codes, and should include a grounding conductor if non-metallic conduit is used.

Field supply wiring must be rated for 600Vac. Use copper conductors.

The electrical installation should include a service disconnect switch in sight of the heater, as well as branch circuit over-current protection and over-temperature protection (if a remote control panel was not provided with the heater).

Where thermocouple extension wire is required between the heater and control panel, verify it is connected with proper polarity as shown on the wiring diagram. Failure to do so may result in an uncontrolled heater. Refer to the wiring diagram for the required wire type. Shielded wire is recommended to reduce signal interference.

Use care when making connections to the heating element to avoid breaking the end ceramic.

WARNING

Retighten all electrical connections that may have loosened during shipment. Failure to do so may result in damage to the heater or risk of fire.

Confirm all unused conduit holes in the terminal box are sealed with plugs suitable for the heater environment.

Attach a ground conductor to the mounting screw for the heater in the terminal box or by other appropriate means per NEC Article 250.

Be sure the terminal box cover is properly installed at all times to ensure personnel protection. Also, contaminants can create leakage, (shock) hazards, permanent heater damage or failure and should be avoided.

It is recommended to perform an insulation resistance test prior to energizing the equipment. If the value is less than 1 Meg ohm using a 500Vdc or similar tester, refer to Maintenance and Troubleshooting sections.

OPERATION

WARNING

DO NOT TURN ON HEATING ELEMENTS UNTIL TANK IS COMPLETELY FULL OF FLUID. Permanent damage may result if elements are energized and the heater is not completely submerged.

To operate this heater, ensure the tank is completely filled with liquid, and energize the main supply disconnect. Set the controlling device to the desired temperature.

During initial heating, it is recommended to slowly ramp up the process set point and inspect the heating system for problems.

DO NOT operate heaters at voltages in excess of that marked on the heater. Excess voltage can shorten heater life or overload the branch circuit wiring.

DO NOT operate heaters at pipe temperatures higher than the recommended maximum. Excess temperatures can cause premature failure. Generally, pipe materials are limited to the following maximum temperatures.

Pipe Material	Maximum Pipe Temperature
Steel	750° F
Stainless Steel 304	1400° F

HEATREX recommends that all safety interlocks be tested during initial startup to ensure they properly disable the heater. After 10 days of operation, retighten all electrical connections.

On flanged heaters, re-tighten heater flange bolts after the heater has completed one or two heating cycles.

MAINTENANCE

CAUTION

Troubleshooting and repairs should only be attempted by qualified maintenance personnel.

WARNING

Hazardous voltages are present in this equipment. Lock out and tag the branch circuit disconnect switch before working on this heater.

Periodically check all electrical connections, including field and factory-made connections for tightness, and all wiring for deterioration at least once a year.

Periodically inspect for leakage and retighten flange bolts when required.

Inspect the terminal enclosure and conduit connections for evidence of water leaks or moisture collection. Tighten connections as required. Do not continue using a heater with signs of damage.

Caution, HEATREX recommends replacing the entire pipe insert assembly under most conditions. The condition of the ceramics

must be considered before attempting to replace coils. Field replaced heating coils must be installed properly or failure may occur.

If field-replacing one or more heating coils, mechanical connections at the end ceramics need to be removed. Remove the burned out coil from both ends by pulling lightly, and at the same time turning the coil back and forth. Check the ceramics near the area where the burnout occurred. Broken ceramics must be replaced, and burn spots should be cleaned with a dry clean paper or cloth towel. Oil or other contamination on the heater coil or ceramics will result in a failure.

The new coil should be stretched to the correct length (do not over stretch), and then inserted from the far end, by lightly pushing with a constant back-and-forth turning motion. After the coil is in place, the loop at the end of the coil should be guided over the bolt on the end ceramic and then tightened in place with the previously removed unit.

Install the heating element back into the pipe as noted in the instructions above.

Where the heater is installed in cold climates, consider safety precautions to prevent damage due to freezing fluid when the heater is not in service.

TROUBLESHOOTING

CAUTION

Troubleshooting and repair should only be attempted by qualified maintenance personnel.

The nature of the ceramic insulators used to electrically isolate and support the nickel chromium resistance wire in the heating elements is such that over a long period of storage, they will absorb considerable moisture from the atmosphere unless the pipe and conduits are sealed. It is recommended to perform an insulation resistance test prior to energizing the equipment. If the value is less than 1 Meg Ohm using a 500Vdc or similar tester, care must be taken to dry out the heater to prevent failure. It is recommended that the elements be turned on at a reduced voltage at first to boil off the moisture. Meg Ohm

readings may drop initially after a few minutes of operation, indicating moisture being forced out of the elements. The terminal enclosure lid should be left open during this period to allow the moisture to escape.

If the heater has a manual-reset high limit thermostat, be sure that the reset button is pressed in.

If reduced heat output is suspected, verify the condition of the heating elements by using an ammeter to check the current draw of each input line. All input lines should draw approximately equal current, which should agree with nameplate rating. If they do not, one or more of the heating elements could be damaged.

HAZARDOUS AREAS

(where applicable)

WARNING – Explosion Hazard

HEATREX strongly recommends installation be performed by qualified personnel familiar with the National Electrical Code and all local codes and standards regarding explosion-proof equipment. It is the responsibility of the installer to verify the safety and suitability of the installation.

Per Article 500-516 of the National Electrical Code, a hazardous area is defined by a "Class", "Division", "Group", and "Temperature Code". The Class can be I or II, where Class I indicates that the hazard classification is due to the presence of an explosive vapor. Class II indicates an explosive dust. The Division can be either 1 or 2. Division 1 indicates a hazard is

ALWAYS considered to be present. Division 2 means the hazard is only present under abnormal conditions. The Group defines the explosiveness of the hazard. The Temperature Code specifies the temperature at which a hazard will ignite.

HEATREX can provide designs suitable for all of the above conditions, but a heater should never be placed in an environment not noted on the heater nameplate.

NEVER operate the heater in an atmosphere with an ignition code temperature LOWER THAN the nameplate rating. The user must determine the actual area classification.

Special design considerations for electric heaters used in hazardous locations:

1. Locate all electrical connections in an appropriate enclosure.
2. Prevent surface temperatures of the heater from exceeding the design ignition temperature.

HEATREX Pipe Insert Heaters designed for hazardous locations are provided with an enclosure designed to contain an explosion.

When the design temperature of the process exceeds the rated ignition temperature, it is critical that the heater and all customer piping is properly insulated.

A hazardous area heater must be powered and controlled by a heater control panel designed to provide necessary over-temperature safety interlocks. Contact HEATREX if assistance is required to properly control and protect the heater.

Never apply power to a heater in a hazardous atmosphere unless all terminal box covers are properly installed with all cover bolts.

All conduits entering the heater terminal box must be sealed within 18" of the heater using an explosion-proof conduit seal. Any unused openings must be properly sealed with a steel pipe plug. Follow the NEC for specific conduit requirements such as the requirement for Rigid Conduit.

To ensure proper flamepath, all threaded conduits must use rated fittings and be tight, with a minimum of 5 good threads engaged. Any machined metal-to-metal surfaces on terminal boxes must be handled carefully to prevent scratches which may void the explosion-proof rating.

WARNING - Risk of Explosion

Operating the heater at a voltage higher than the nameplate value may result in elevated temperatures and amperage above the design ratings.

Proper grounding of equipment in hazardous areas is critical to eliminate potential sources of sparking.

Replacement of electrical components should only be done by authorized personnel familiar with the requirements of maintaining electrical equipment in an explosion-hazard area.

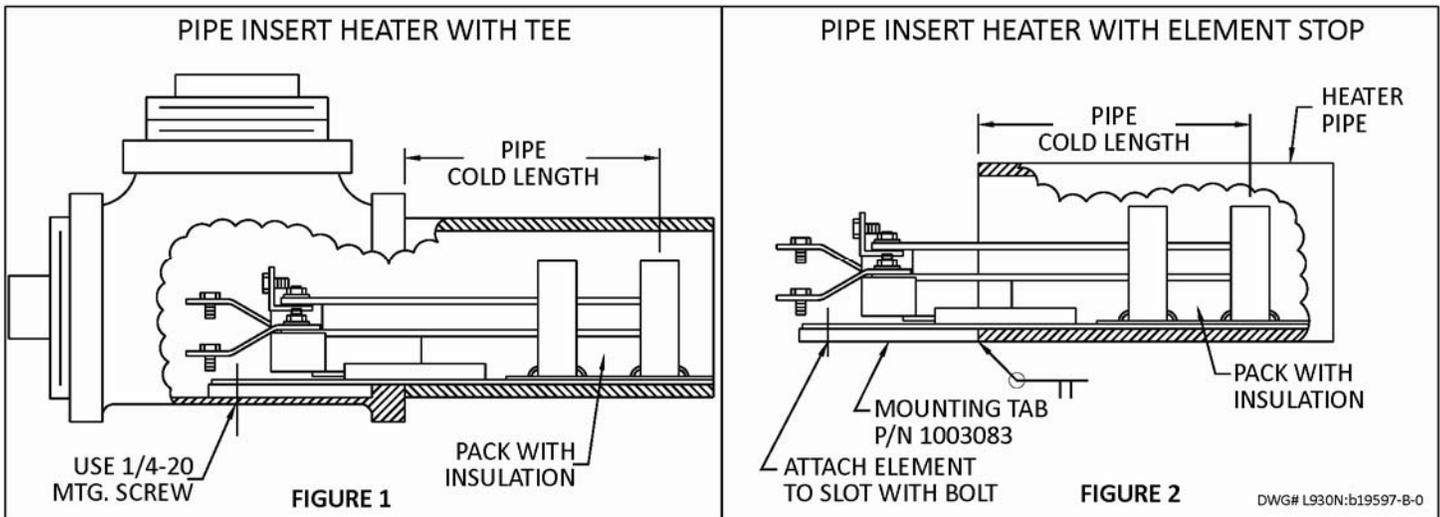

Phone: 814-724-1800
www.heatrex.com

HX79-2150-83-1